

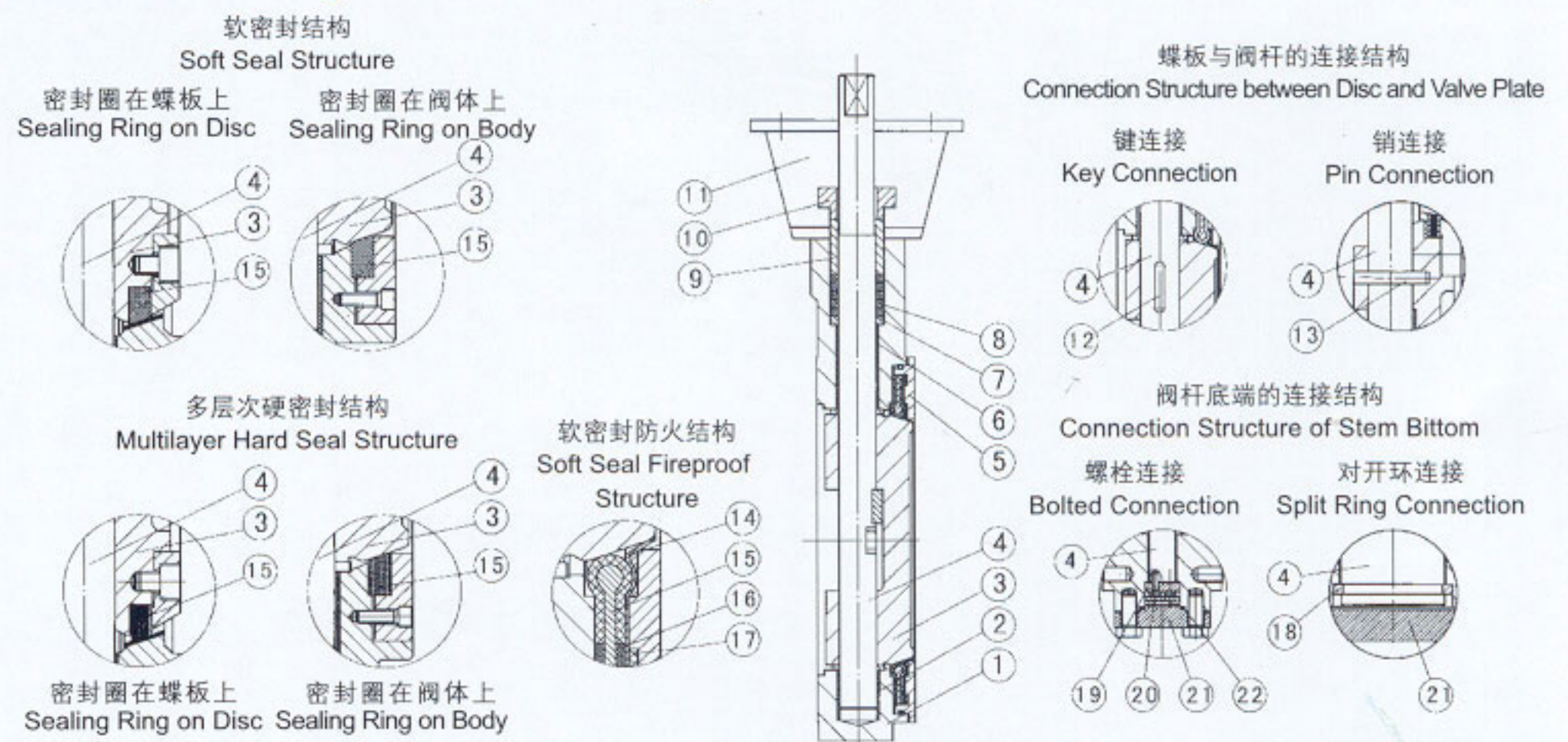

单偏心蝶阀结构特征 Design characteristics of single eccentric butterfly valve



主要零件材料 Materials For Main Parts

序号 No.	零件名称 Part Name	材料 Materials	可选材料 Optional Materials
1	阀体 Body	铸钢 Cast Steel	不锈钢、蒙乃尔 SS, Monel
2	下轴套 Bushing	聚四氟乙烯+黄铜 PTFE+Bronze	自润滑黄铜 Luberized Bronze
3	蝶板 Disc	铸钢 Cast Steel	不锈钢、蒙乃尔 SS, Monel
4	阀杆 Stem	不锈钢 SS	不锈钢、蒙乃尔 316, Monel
5	压板圈 Retainer Flange	碳钢 Carbon Steel	不锈钢、蒙乃尔 SS, Monel
6	上轴套 Bushing	聚四氟乙烯+黄铜 PTFE+Bronze	自润滑黄铜 Luberized Bronze
7	填料垫 Packing Seat	不锈钢 SS	不锈钢、蒙乃尔 SS, Monel
8	填料 Packing	柔性石墨 Graphite	PTFE
9	填料压套 Packing Bushing	不锈钢 SS	不锈钢 SS
10	填料压板 Gland	碳钢 Carbon Steel	不锈钢 SS
11	连接支架 Yoke	碳钢 Carbon Steel	-
12	键 Key	不锈钢 SS	不锈钢、蒙乃尔 SS, Monel
13	销轴 Pin	不锈钢 SS	蒙乃尔 Monel
14	防火圈 Metalseat tongue	不锈钢 SS	不锈钢 SS
15	密封圈 Seal Ring	PTFE+SS	NBR/SS+Graphite
16	垫片 Gasket	柔性石墨 Graphite	
17	垫片 Gasket	柔性石墨 Graphite	
18	对开圆环 Half ring	不锈钢 SS	不锈钢、蒙乃尔 SS, Monel
19	限位块 Limit Bland		
20	螺栓 bolts	B7	不锈钢 SS
21	底盖 Cover	碳钢 Carbon Steel	不锈钢、蒙乃尔 SS, Monel
22	垫片 Gasket	柔性石墨 +ss	Graphite+ss

产品性能规范 Chief property And Specification

设计标准 Design Standard	GB/T12238	API609
压力温度等级 Pressure-Temperature Rating	GB/T12224	API609,ASME B16.34
结构长度 Face-Face	GB/T12221	API609,ISO5752,ASME B16.10
法兰型式尺寸 Flange Ends	GB/T9113、JB/T79	ASME B16.5\B16.47
检验与试验 Inspection &Test	JB/T9092、GB/T13927	API598
公称压力 NominalPressure(MPa)	1.0 1.6 2.5 4.0	CLASS150 CLASS300
壳体试验 Shell Test	1.5 2.4 3.75 6.0	2.93 7.58
试验压力 (MPa) Test Pressure	高压密封 High Pressure Seal Test 1.1 1.76 2.75 4.4	2.07 5.52
	低压密封 Low Pressure Seal Test 0.6	0.6
适用温度 Applicable Temperature	- 196℃~550℃ (不同的工况温度选用不同的材质) Different raw material for different work temperature	
适用介质 Applicable Medium	水、油、气及各类腐蚀性介质(不同的介质选用不同的材质) Water, oil, gas and other causticity medium(Different raw material for different medium)	

单偏心对夹式蝶阀 SINGLE ECCENTRIC WAFFLE BUTTERFLY VALVE

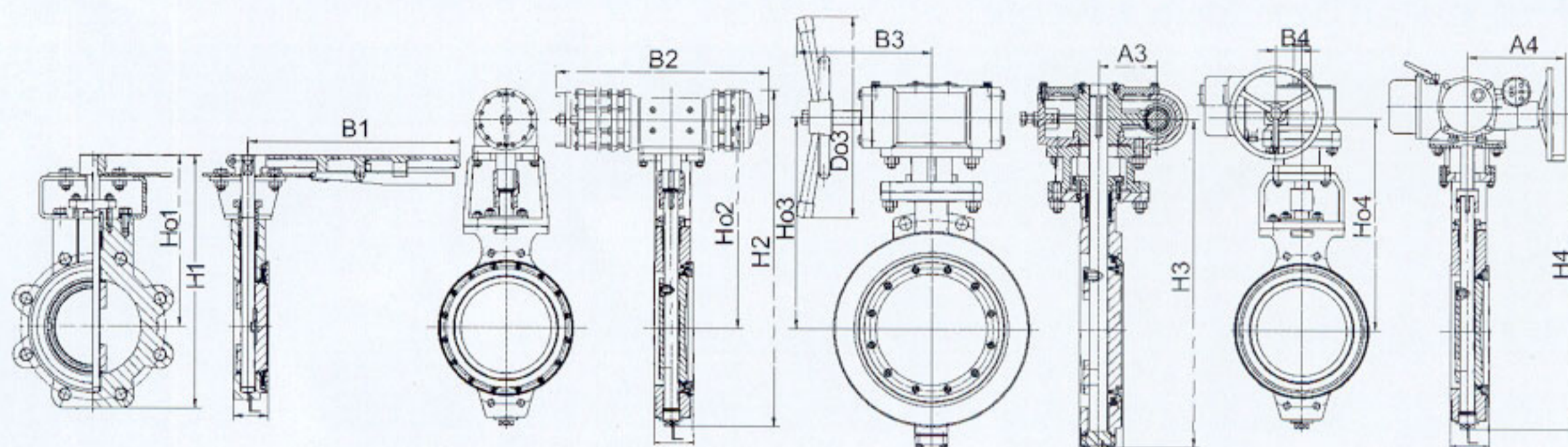

手动凸耳对夹式蝶阀 气动对夹式蝶阀 蜗轮蜗杆传动对夹式蝶阀 电动对夹式蝶阀
Manual Lug Wafer Butterfly Valve Pneumatic Wafer Butterfly Valve Worm Gear Driven Wafer Butterfly Valve Electric Wafer Butterfly Valve

主要外形尺寸和重量 Main Dimensions & Weight

PN 0.6MPa

DN	L	手动			气动			蜗轮蜗杆传动					电动				重量kg	
		H1	Ho1	B1	H2	Ho2	B2	H3	Ho3	B3	A3	Do3	H4	Ho4	B4	A4	WF	WL
50	43	233	160	200	-	-	-	266	143	106	50	160	-	-	-	-	4.5	5.5
65	46	275	179	230	-	-	-	290	178	140	63	180	-	-	-	-	5	7
80	49	316	198	250	-	-	-	320	185	140	63	180	320	185	178	180	6	9
100	56	341	211	270	-	-	-	342	193	140	63	240	340	198	178	180	8	11.5
125	64	362	217	300	-	-	-	378	219	140	63	240	340	205	178	180	12	17
150	70	384	235	350	-	-	-	415	245	140	63	240	415	241	178	180	13	22
200	71	-	-	-	695	325	275	470	298	170	84	300	512	263	235	370	20	39
250	76	-	-	-	750	355	275	535	328	170	84	300	570	292	235	370	30	47
300	83	-	-	-	935	475	378	606	365	200	108	400	668	340	235	370	51	68
350	92	-	-	-	1000	510	378	695	408	200	108	400	745	385	235	370	82	135
400	102	-	-	-	1145	590	378	755	446	240	128	400	827	425	235	370	115	187
450	114	-	-	-	1205	632	530	815	475	330	144	600	915	462	235	370	156	225
500	127	-	-	-	1256	665	530	905	525	370	220	600	995	500	235	370	199	260
600	154	-	-	-	1526	830	530	1050	610	370	220	600	1183	605	245	515	333	383
700	165	-	-	-	1640	903	530	1276	795	515	279	800	1460	734	245	515	462	510
800	190	-	-	-	1786	972	680	1384	837	515	279	800	1589	803	245	515	740	920
900	203	-	-	-	1917	1052	680	1505	885	515	279	800	1856	990	360	540	701	1189
1000	216	-	-	-	2600	1170	680	1620	946	570	368	600	1958	1050	360	540	786	1220
1200	254	-	-	-	-	-	-	2185	1165	570	378	600	2013	1165	360	540	907	1660

PN 1.0MPa

DN	L	手动			气动			蜗轮蜗杆传动					电动				重量kg	
		H1	Ho1	B1	H2	Ho2	B2	H3	Ho3	B3	A3	Do3	H4	Ho4	B4	A4	WF	WL
50	43	233	160	200	-	-	-	266	143	106	50	160	-	-	-	-	4.5	5.5
65	46	275	179	230	-	-	-	290	178	140	63	180	-	-	-	-	5	7
80	49	316	198	250	-	-	-	320	185	140	63	180	320	185	178	180	6	9
100	56	341	211	270	-	-	-	342	193	140	63	240	340	198	178	180	8	11.5
125	64	362	217	300	-	-	-	378	219	140	63	240	340	205	178	180	12	17
150	70	384	235	350	-	-	-	415	245	140	63	240	415	241	178	180	13	22
200	71	-	-	-	695	325	275	470	298	170	84	300	512	263	235	370	20	39
250	76	-	-	-	750	355	275	535	328	170	84	300	570	292	235	370	30	47
300	83	-	-	-	935	475	378	606	365	200	108	400	668	340	235	370	51	68
350	92	-	-	-	1000	510	378	695	408	200	108	400	745	385	235	370	82	135
400	102	-	-	-	1145	590	378	755	446	330	144	400	827	425	235	370	115	187
450	114	-	-	-	1205	632	530	815	475	330	144	600	915	462	235	370	156	228
500	127	-	-	-	1256	665	530	905	525	370	220	600	995	500	235	370	199	260
600	154	-	-	-	1526	830	530	1050	610	370	220	600	1183	605	245	515	333	383
700	165	-	-	-	1640	903	530	1276	795	515	279	800	1460	734	245	515	462	510
800	190	-	-	-	1786	972	680	1384	837	515	279	800	1589	803	245	515	740	920
900	203	-	-	-	1917	1052	680	1505	885	515	279	800	1856	990	360	540	701	1189
1000	216	-	-	-	2600	1170	680	1620	946	570	368	600	1958	1050	360	540	786	1220
1200	254	-	-	-	-	-	-	2185	1165	570	378	600	2013	1165	360	540	907	1660



主要外形尺寸和重量 Main Dimensions & Weight

PN 1.6MPa

DN	L	手动			气动			蜗轮蜗杆传动					电动				重量kg	
		H1	Ho1	B1	H2	Ho2	B2	H3	Ho3	B3	A3	Do3	H4	Ho4	B4	A4	WF	WL
50	43	225	160	200	-	-	-	266	143	160	106	50	-	-	-	-	4.5	5.5
65	46	250	175	230	-	-	-	290	175	160	140	63	-	-	-	-	7	7
80	49	260	190	250	-	-	-	320	185	160	140	63	513	265	178	180	9	9
100	56	295	195	270	-	-	-	342	195	160	140	63	538	282	178	180	20	11.5
125	64	330	215	300	-	-	-	365	209	300	140	63	560	295	178	180	23	17
150	70	356	225	350	-	-	-	415	243	300	140	63	605	300	178	180	29	22
200	71	-	-	-	695	327	275	510	268	400	150	84	749	321	235	370	40	39
250	76	-	-	-	750	355	275	567	295	400	150	84	803	330	235	370	50	47
300	83	-	-	-	955	472	378	665	342	600	200	108	880	365	235	370	68	68
350	92	-	-	-	1033	515	378	739	385	600	200	108	960	410	235	370	105	138
400	102	-	-	-	1185	595	530	825	430	600	240	152	1032	445	235	370	163	190
450	114	-	-	-	1270	632	530	910	469	330	144	600	1118	487	235	370	205	230
500	127	-	-	-	1335	665	530	990	500	370	220	600	1190	520	235	370	270	265
600	154	-	-	-	1642	829	680	1210	618	370	220	600	1380	625	235	370	390	437
700	165	-	-	-	1785	905	680	1475	746	515	279	800	1582	745	245	515	465	740
800	190	-	-	-	1915	970	680	1600	810	515	279	800	1713	810	245	515	570	920
900	203	-	-	-	-	-	-	1870	1000	515	279	800	1870	875	360	540	701	1189
1000	216	-	-	-	-	-	-	2000	1065	570	368	600	2000	940	360	540	800	1220
1200	254	-	-	-	-	-	-	2215	1170	570	378	600	2118	1060	360	540	922	1680

PN 2.5MPa

DN	L	手动			气动			蜗轮蜗杆传动					电动				重量kg	
		H1	Ho1	B1	H2	Ho2	B2	H3	Ho3	B3	A3	Do3	H4	Ho4	B4	A4	WF	WL
50	43	225	160	200	-	-	-	266	143	106	50	160	-	-	-	-	6.3	6.3
65	46	250	175	230	-	-	-	290	175	140	63	160	-	-	-	-	9	9.2
80	49	260	190	250	-	-	-	513	265	63	140	160	552	265	178	180	11	11
100	56	295	195	270	-	-	-	538	282	63	140	300	585	290	178	180	25	15
125	64	330	215	300	-	-	-	560	295	63	140	300	610	305	178	180	33	17
150	70	356	225	350	-	-	-	605	300	63	140	400	765	315	178	180	47	22
200	71	-	-	-	695	327	275	749	321	84	150	400	820	304	235	370	52	39
250	76	-	-	-	750	355	275	803	330	84	150	600	910	336	235	370	65	47
300	83	-	-	-	955	472	378	880	365	108	200	600	1000	386	235	370	68	123
350	92	-	-	-	1033	515	378	960	410	108	240	600	1055	425	235	370	138	190
400	102	-	-	-	1185	595	530	1032	445	128	240	800	1108	456	235	370	190	230
450	114	-	-	-	1270	632	530	1118	487	330	144	600	1140	490	235	370	230	265
500	127	-	-	-	1335	665	530	1190	520	370	220	600	1238	552	235	370	265	390
600	154	-	-	-	1642	829	680	1380	625	370	220	600	1399	635	245	515	437	465
700	165	-	-	-	1785	905	680	1582	745	515	279	800	1611	750	360	540	570	740
800	190	-	-	-	1915	970	680	1713	810	515	279	800	1782	820	360	540	705	920
900	203	-	-	-	-	-	-	1870	875	515	279	800	1915	886	385	565	730	1189
1000	216	-	-	-	-	-	-	2000	940	570	368	600	2040	945	385	565	927	1220
1200	254	-	-	-	-	-	-	2118	1060	570	378	600	2184	1053	400	770	953	1680

PN 4.0MPa

DN	L	手动			气动			蜗轮蜗杆传动					电动				重量kg	
		H1	Ho1	B1	H2	Ho2	B2	H3	Ho3	B3	A3	Do3	H4	Ho4	B4	A4	WF	WL
50	43	225	160	200	-	-	-	266	143	106	50	200	-	-	-	-	6.3	7.3
65	46	265	175	230	-	-	-	290	175	143	80	250	-	-	-	-	9	9.8
80	49	275	190	270	-	-	-	395	245	143	80	300	530	240	178	180	11	11.5
100	56	310	205	300	-	-	-	356	205	200	108	400	555	205	178	180	25	29
125	64	347	220	350	-	-	-	375	213	200	108	400	582	215	178	180	33	38
150	70	374	235	380	-	-	-	439	260	200	108	600	609	260	235	370	47	51
200	71	-	-	-	750	375	275	520	275	330	140	600	755	275	235	370	55	67
250	76	-	-	-	905	445	378	600	315	330	140	600	818	315	235	370	70	70
300	83	-	-	-	1085	538	503	692	365	370	220	800	912	363	245	515	135	142
350	92	-	-	-	1160	576	503	776	408	370	220	800	983	406	245	515	203	227
400	102	-	-	-	1230	609	503	864	443	370	220	800	1058	440	245	515	245	268
450	114	-	-	-	1520	765	680	1128	525	512	279	400	1135	545	360	540	283	333
500	127	-	-	-	1335	665	530	1257	664	512	279	400	1245	600	360	540	405	520
600	154	-	-	-	-	-	-	1380	625	512	279	400	1414	663	360	540	591	645
700	165	-	-	-	-	-	-	1435	712	570	368	600	-	-	-	-	723	785
800	190	-	-	-	-	-	-	1518	782	570	368	600	-	-	-	-	846	935

注：表中为无驱动装置重量。WF为对夹式蝶阀（WAFER），WL为凸耳对夹式蝶阀（LUG）

Note: the weight in the table is that without drive unit. WF is wafer butterfly valve, and WL is lug wafer butterfly valve.