

产品执行标准 Production enforce standard

产品规范 Product Specification	设计规范 Design Dpec	结构长度 Face to Face	对焊端 Bwend	试验与检验 Test & Check	压力-温度 Pressure-Temp.	产品标识 Marking	供货规范 Supply
	JB/T 3595/E101	JIS E101	ANSI B16.25	JIS E101	JB/T 3595	GB/T 12220	JISE101

产品性能规范 Chief property and specification

产品型号 Product type	公称压力 PN(MPa) Nominal pressure	试验压力(MPa)Test pressure		工作压力(MPa) Working pressure			工作温度(°C) Working temperature	适用介质 Applicable medium
		壳体强度 Shell strength test	密封 Sealing	P54	P55	P57		
J61 ^H -100	10	15	11	/	/	/	≤450	水、蒸汽、油品 Water, stesm, oil goods
J61 ^H -200	20	30	22	/	/	/		
J61 ^H -250	25	38	28	/	/	/		
J61 ^H -320	32	48	36	/	/	/		
J61Y-P54/100V	/	30	22	10	/	/	≤540	蒸汽 Stesm
J61Y-P54/140V	/	38	28	14	/	/		
J61Y-P54/170V	/	48	36	17	/	/		
J61Y-P55/100V	/	38	28	/	10	/	≤555	
J61Y-P55/140V	/	48	36	/	14	/		
J61Y-P55/170V	/	53	39	/	17	/		
J61Y-P57/100V	/	48	36	/	/	10	≤570	
J61Y-P57/140V	/	55	40	/	/	14		
J61Y-P57/170V	/	60	44	/	/	17		

主要零部件材料 Material for Main Parts

零件名称 Part Name	零部件材料 Part Material		
阀体 Body	WCB(A105N)	WC6(F11)	WC9(F22)
闸盖 Bonnet	25	12Cr1Mo1VA	
闸板 Wedge	25	20Cr1Mo1VA	20Cr1Mo1VA
阀杆 Stem	1Cr17Ni2	20Cr1Mo1VA	
阀座 Seat	25	12Cr1Mo1VA	
密封副 Hard Trim	STL+STL	STL+STL	STL+STL
填料 Packing	柔性石墨/Flexible Graphite		
垫片 Gasket	S软钢/柔性石墨 Soft-Iron/Flexible Graphite	S软钢 Soft-Iron	F软钢 F Soft-Iron
适用温度 Sutable Temp.	-29~425°C		-29~540°C
适用介质 Sutable Medium	水、油品、蒸汽 Water, oil, stesm		蒸汽、油品 stesm, oil

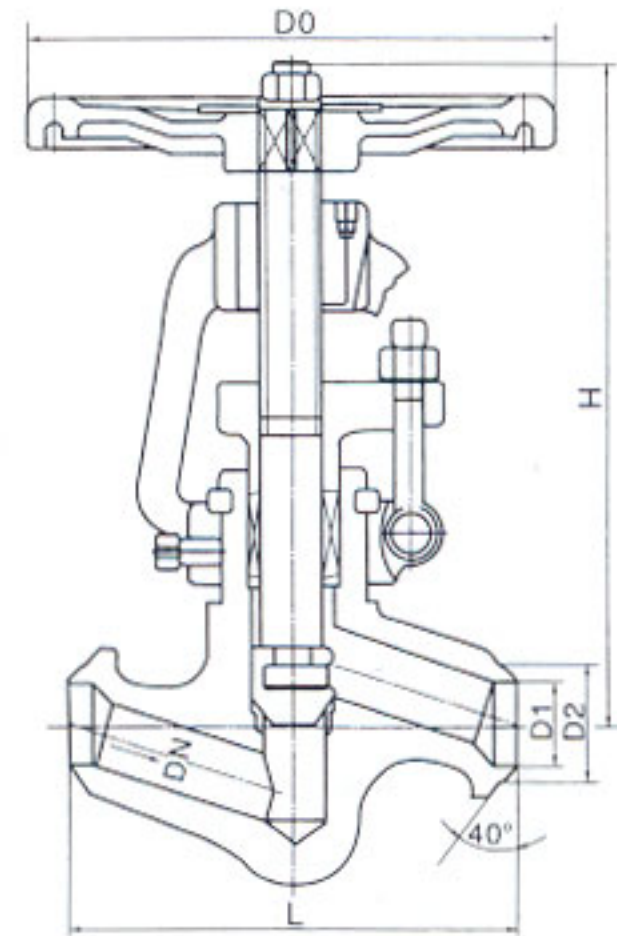
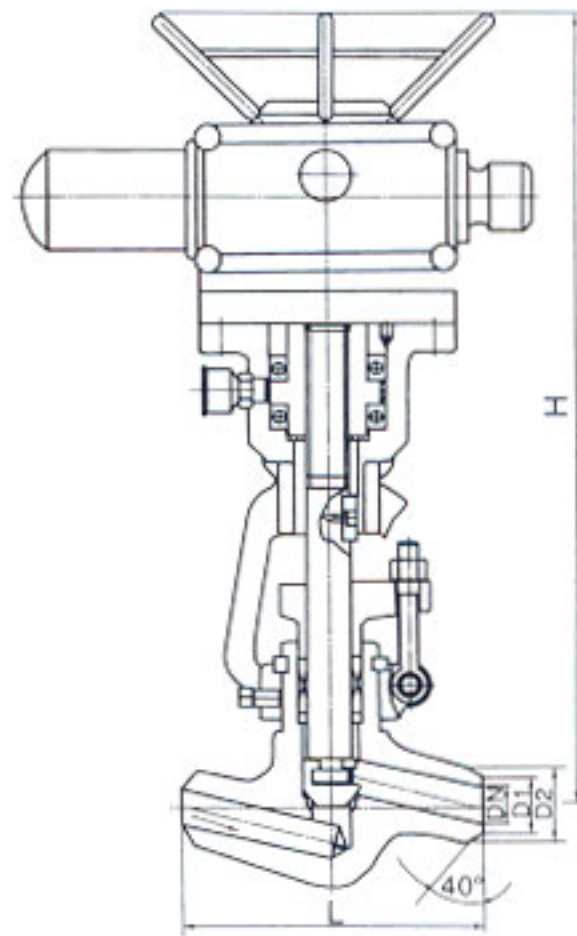
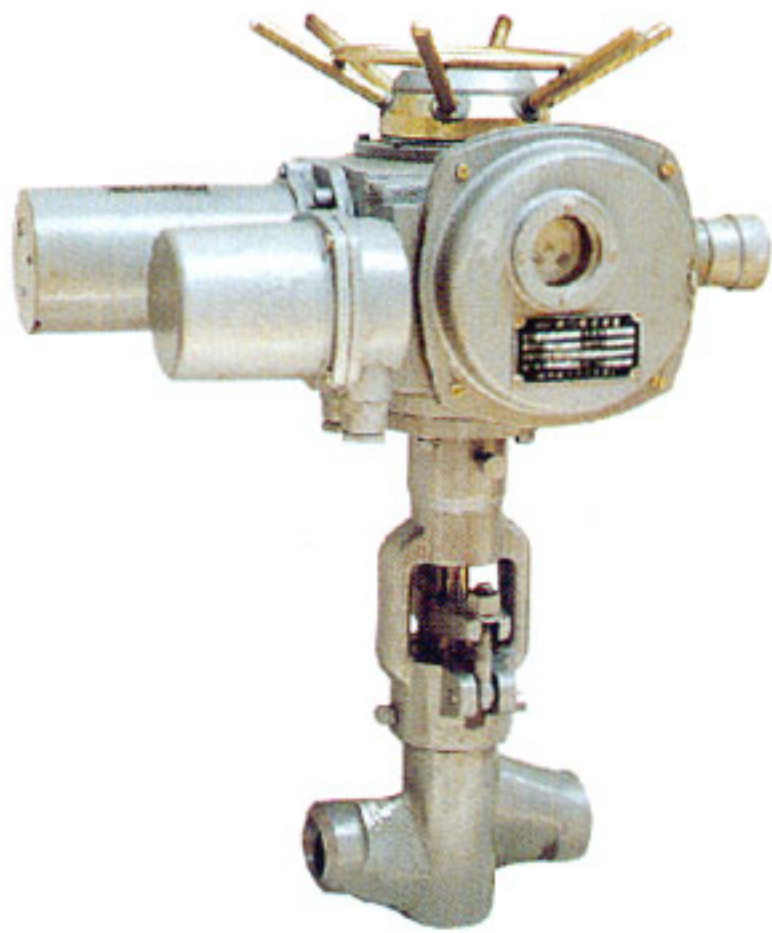

主要外形尺寸及重量 Main Dimension & weight

公称通径 DN	L	D1	D2	H	WT(Kg)
J61H-200 J61Y-200 J961H-200 J961Y-200					
20	170	22	42	480	38
25	170	27	42	520	41
32	200	34	52	728	58
50	350	53	76	728	89
80	500	86	108	798	135
100	600	107	161	890	190
J61H-250 J61Y-320 J961H-250 J961Y-320					
20	150	25	40	576	47
25	170	27	42	585	49
32	180	32	55	606	52
50	250	50	83	722	73
80	470	80	105	895	225
100	600	100	142	1179	296

主要外形尺寸及重量 Main Dimension & weight

公称通径 DN	L	D1	D2	H	WT(Kg)
J61Y-P54100V J61Y-P54140V J96Y-P54100V J96Y-P54100V					
20	170	22	42	480	38
25	170	27	42	520	41
32	200	34	52	728	58
50	350	53	76	728	89
80	500	86	108	798	135
100	600	107	161	890	190
J61Y-P54170V J61Y-P54195V J96Y-P54170V J96Y-P54195V					
20	150	25	40	576	47
25	170	27	42	585	49
32	180	32	55	606	52
50	250	50	83	722	73
80	470	80	105	895	225
100	600	100	142	1179	296